

*Circle your lab day and time.*

Your name: _____	<b>Mon</b>	<b>Tue</b>	<b>Wed</b>	<b>Thu</b>	<b>Fri</b>
TA name: _____	<b>8-10</b>	<b>10-12</b>	<b>12-2</b>	<b>2-4</b>	<b>4-6</b>

## Lab 6: AC Signals

### INTRODUCTION

In this experiment, you will use an oscilloscope to measure the time-varying (AC) voltages from two quite different sources: a signal generator and your heart.

Take a look at the appendix (now!) if you have never used an oscilloscope!

### PART I: MEASURING THE FREQUENCY RANGE OF YOUR HEARING

At your table you should have a speaker, a signal generator, a microphone, and an oscilloscope. The speaker is driven by a signal generator which produces a sinusoidal voltage of adjustable frequency and amplitude. Note that there are both coarse and fine adjust knobs for the frequency, as well as “decade” buttons which can adjust the frequency by factors of 10.

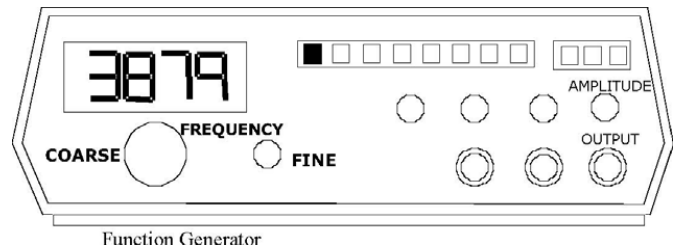

Connect the signal generator directly to the oscilloscope and turn it on. Adjust the amplitude of the signal generator and the scales of the oscilloscope so that you see a couple of complete sine waves on your scope.

- Write down the frequency setting of the signal generator:
  
- From the oscilloscope trace, calculate the period of the alternating voltage signal.
  
- From this, calculate the frequency.
  
- Does your oscilloscope measurement match the setting on the signal generator? If not, why not?

Turn down the amplitude on the signal generator. Now connect the signal generator to the speaker, and connect the microphone to the oscilloscope. Turn the volts/div knob on the oscilloscope all the way up, to maximize its sensitivity. Place the microphone near the speaker and adjust the signal generator amplitude up until you can see a signal. Adjust the frequency and amplitude until you can hear a mid-range tone at a quiet but audible volume.

- Record the frequency setting on the signal generator:
  
- Calculate the period and frequency of the wave from the oscilloscope.
  
- Do they match? If not, why not?

Devise and carry out a simple method with this equipment to experimentally measure the frequency range of your own hearing (which means to identify the highest and lowest frequencies you can easily detect with your ears) and those of your partners. Record your results in the table below.

Lab Partner	Lowest Frequency	Highest Frequency

- Is this range the same for everyone in your group?

When you are done with this part, turn off the little switch on the microphone to save the batteries.

## PART II: LOOKING AT YOUR HEARTBEAT

Every living person's heart produces electrical signals that can be measured on the surface of the skin. An EKG (electrocardiograph) is an instrument that can measure these signals and produce a visual image (and sometimes an audible sound, as in the "beep ... beep ... beep ..." you hear in movies). Your goal for this experiment is to obtain an accurate recording of this voltage signal from one of your lab mates, and to determine what things affect this signal. Our makeshift electrocardiograph is an oscilloscope with two large copper terminals and an amplifier (some details are in your textbook, section 17-11).

Your heart is a complicated electrochemical machine that produces time-varying voltages as it beats. These heart voltages produce small voltage differences between points on your skin that can be measured and used to diagnose the condition of your heart. Usually nine electrodes, positioned at various points of the patient's body, are used when recording a full electrocardiogram. However, in this lab, we will only use two electrodes to measure  $\Delta V$  between your right and left hands.

A typical plot of voltage difference between two points on the human body vs. time is shown in the figure to the right. The **P** deflection corresponds to the contraction of the atria at the start of the heart beat. The **QRS** group corresponds to the contraction of the ventricles. The **T** deflection corresponds to a recovery (or re-polarization) of the heart cells in preparation for the next beat. Every heart pattern is slightly different, and the interpretation of an EKG requires experience with many patients.

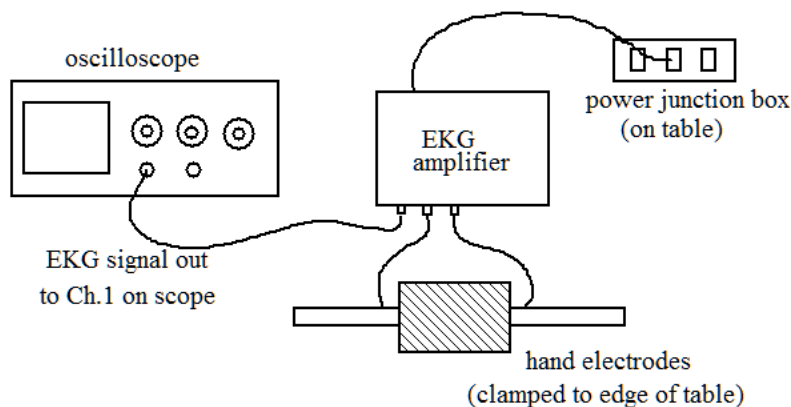
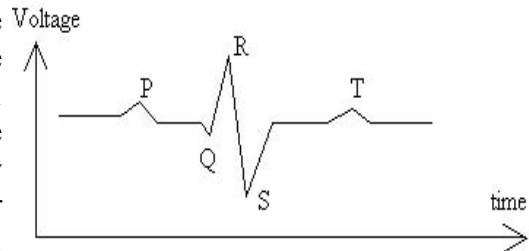

The EKG apparatus that you will use consists of two electrodes, an amplifier, and a storage oscilloscope. Signals travel from the hands, one placed on each electrode, to the EKG amplifier and then on to the oscilloscope. The voltage that is measured is the potential difference between the two electrodes. However, the voltage difference between your hands is inconveniently small to measure directly. To compensate for this, the signal from the electrodes is given a boost by the amplifier.

### OSCILLOSCOPE SETUP

1. The oscilloscope needs to be switched from "AC" to "DC" (right above the BNC input).
2. The volts/division dial should be set at **0.1** and the time/division dial should be set at **0.1**.

3. Triggering (over on the right side of the oscilloscope) should be set to “auto.”

- A. The voltage displayed on the oscilloscope differs from the input voltage of your hands by an amplification factor. To find this factor, switch the amplifier mode to “**calibrate**” and then press the red button — this produces an **input** voltage whose peak (positive) value is  $1 \text{ mV} = 10^{-3}$  volts.
  - Measure the voltage on the oscilloscope to calculate the amplification factor of your amplifier. (Even though the amplification factor has no physical units, it may be helpful to assign the amplification factor units of  $[V_{\text{output}}/V_{\text{input}}]$ ).
  
- B. Have one person in your group sit down in front of the electrode assembly with his or her hands wrapped *gently* around the electrodes, palms down. Adjust the settings on the oscilloscope until you can see a full EKG signal on the screen.
  - Draw a picture of the EKG and record any specific details of the signal that you can measure. Be sure to record the settings of the oscilloscope scale knobs.

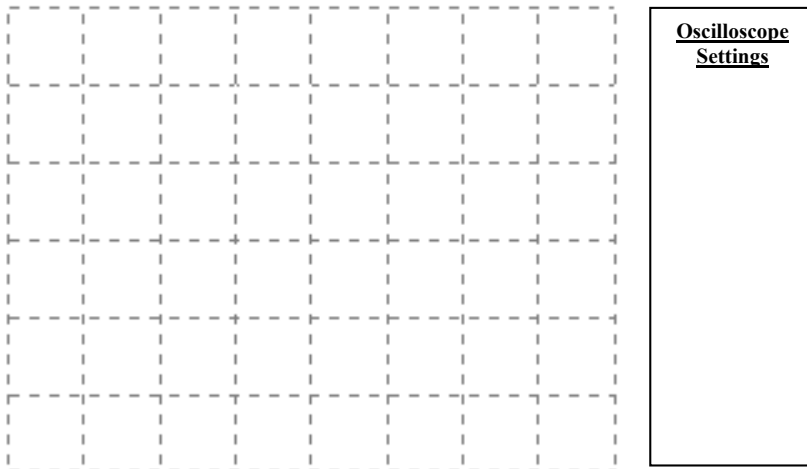

- Including the amplification factor, what is the actual voltage produced by your lab mate’s heart?
  
- C. Grab and squeeze the electrodes hard with your hands.
  - What happens to the voltage signal? What could explain this?

D. Adjust the oscilloscope so you can see at least two peaks on the screen and record your observations.

- Measure a lab partner’s pulse rate from this data. Using the grid, draw the EKG. Make sure you include the oscilloscope settings.
- Repeat the previous steps with a second (or more) member(s) of your group, drawing the new EKG on top of the first EKG. Include a key that shows which EKG belongs to which person.

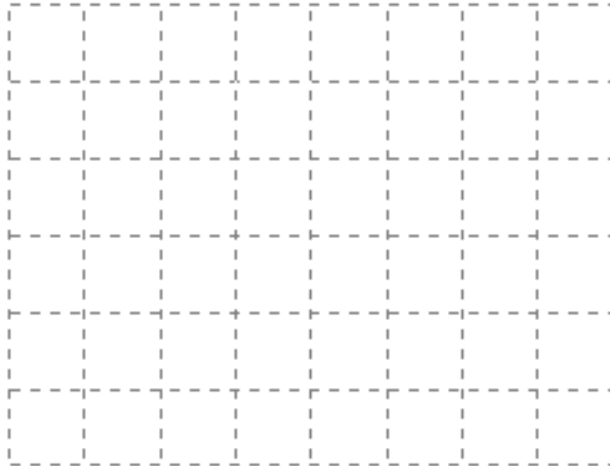

Oscilloscope Settings

  
  
  
  

KEY

Comment on the similarities and differences between the traces.

- How should your plots differ?
  
  
  
- In what aspects should they be the same?
  
  
  
- Do your plots fit these expectations? If not, why not?

E. Have someone in your group reverse his or her hands on the electrodes and again make a careful drawing of the resulting EKG trace in such a way as to facilitate comparison with the previous plot.

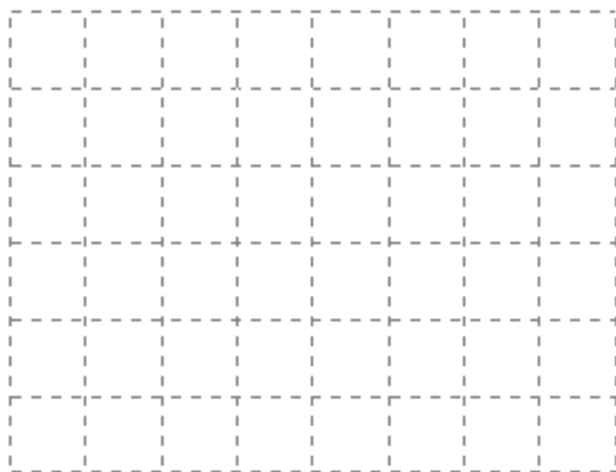

- How should your plots differ?
  
  
  
- In what aspects should they be the same?
  
  
  
- Do your plots fit these expectations? If not, why not?

Oscilloscope Settings

F. After everyone in your lab group feels they have a solid understanding of what you are measuring and how you exactly do it, predict what would happen if two people holding hands were to touch the electrodes (that is, one person grabs it with their right hand and the other person grabs the other electrode with their left hand).

- Record your prediction (including drawing and explanation).

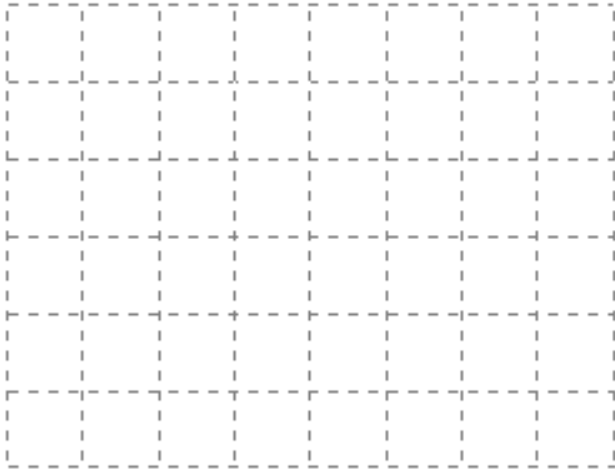

- Test your prediction it to see if you're right.

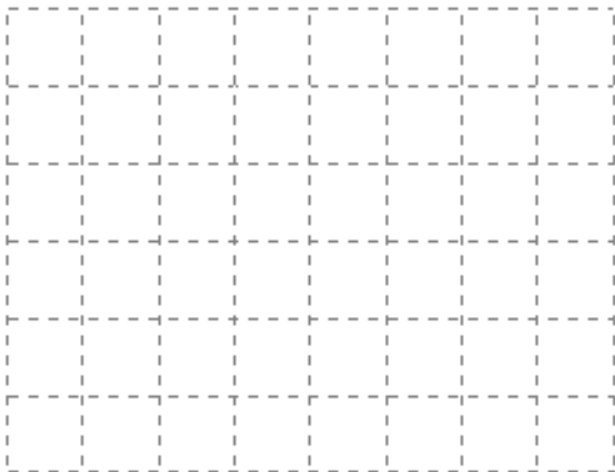

Oscilloscope  
Settings

## APPENDIX: USING THE OSCILLOSCOPE

Almost every AC measurement is done using an **oscilloscope**, which is a very useful tool for measuring voltages that are changing in time. Think of the oscilloscope just like the DMM you have used in previous labs – it measures voltage, but now it plots it out in time (voltage on the vertical axis and time on the horizontal axis). The grid that you see on the screen is used to measure the voltage and time of your signal – think of it like graph paper. Each little box on the grid is called a *division*, and you can adjust the scale of the voltage and time axes with the **volts/div** and the **sec/div** knobs, respectively. For example, if the volts/div knob is set to "5", this means that each box on the grid is equal to 5 volts.

There is small knob in the center of both the volts/div and time/div knobs, called the CAL or calibration knob. This should always be in the fully CW position in order for the volt/div and sec/div scale settings to be correct. Under the volts/div knob is a 3-position switch which reads (AC - ground - DC). This should be in the AC position for AC measurements.

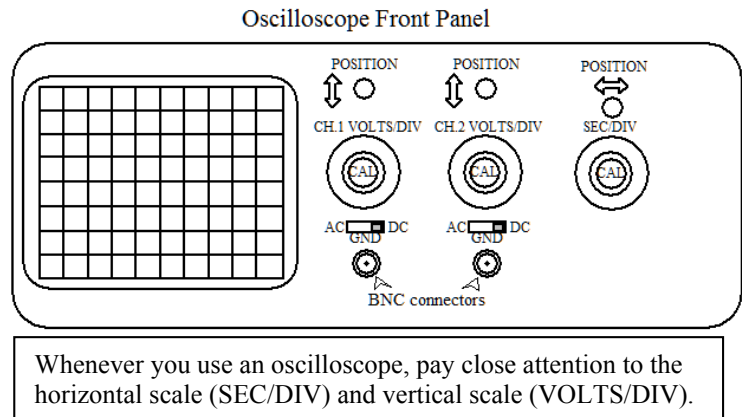

When connecting the various components to each other, you will be using two different types of cables: coaxial cables with BNC connectors and single cables with banana-plug connectors. The different types of connectors are shown below:



**BNC cable**



**Banana plugs**



**Banana-to-BNC adapter**

When hooking things up, be aware that there is often a grounded side on plugs. You should be sure that grounded sides match up, e.g. when connecting to banana to BNC adapter. (Ground is generally marked by a square-ish tab.)

FYI: BNC cables are actually two cables in one. They are composed of an inner conductor, which is connected to the pin on the connector, and an outer conductor, which is connected to the metal housing. The outer conductor surrounds the inner conductor, so it is a **coaxial** cable. In many configurations, the outer conductor is always kept at 0 volts. (The outer conductor is sometimes referred to as “grounded” for this reason.) The two conductors are separated by an insulating material that is designed to maintain a constant spacing between them.